



Single Ended Recuperative Burners

Model SER 600

Version 3

PARAMETER		Burner Input 1000's Btu/Hr (Kw)			
		50 (14.6)	100 (29.3)	150 (44.0)	200 (58.6)
Low firing rate 1000's Btu/hr (kW) Between 150-220% excess air		5 (1.5)	5 (1.5)	10 (2.9)	10 (2.9)
Differential air pressure "w.c. (mbar) between tap A and C (See Pages 3 & 4)		4.9 (12.2)	2.8 (7.0)	6.3 (15.7)	6.4 (15.9)
Recommended air orifice diameter mm		15	22	22	25
Air Flow (SCFH) At 15% excess air		575	1150	1725	2300
Differential gas pressure "w.c. (mbar) between tap B and D (See Pages 3 & 4)	nat. gas	4.4 (10.9)	3.0 (7.5)	6.1 (15.2)	4.7 (11.7)
	propane	3.5 (8.7)	4.2 (10.5)	3.2 (7.9)	5.4 (13.4)
	butane	3.0 (7.5)	2.7 (6.7)	6.0 (14.9)	3.7 (9.2)
Recommended gas orifice plate mm	nat. gas	3.8	5.8	5.8	7.2
	propane	3.0	4.2	5.5	5.5
	butane	3.0	4.2	4.2	5.5
Piping		N.P.T. or B.S.P. interface is available.			
Flame detection	U.V. Scanner	Natural Gas only			
	Flame Rod	Natural Gas, propane, butane			
Ignition		direct spark ignition (6 kVAC)			
Fuels		Natural gas, propane, butane <i>For any other mixed gas, contact Eclipse Combustion</i>			

 Note: Air supply pressure required at the burner inlets is shown on page 2. Gas pressure should be at least 1" w.c. (2.49 mbar) less than air pressure.

- The low firing rate represents the capability of the burner. Achievement of this rate will be affected by the control method and ratio-regulator used in the system design. Typical ratio regulators provide a 10 to 1 turndown from high to low fire.
- All inputs based on gross caloric values.
- Eclipse reserves the right to change the construction and/or configuration of our products at any time without being obliged to adjust earlier supplies accordingly.
- Plumbing of air and gas will affect accuracy of orifice readings. All information is based on generally acceptable air and gas piping practices.
- Maximum furnace temperature is 1850°F (1010°C)
- For vertical applications, contact Eclipse Sales Representative.

Performance Graphs
SER600 v3.00

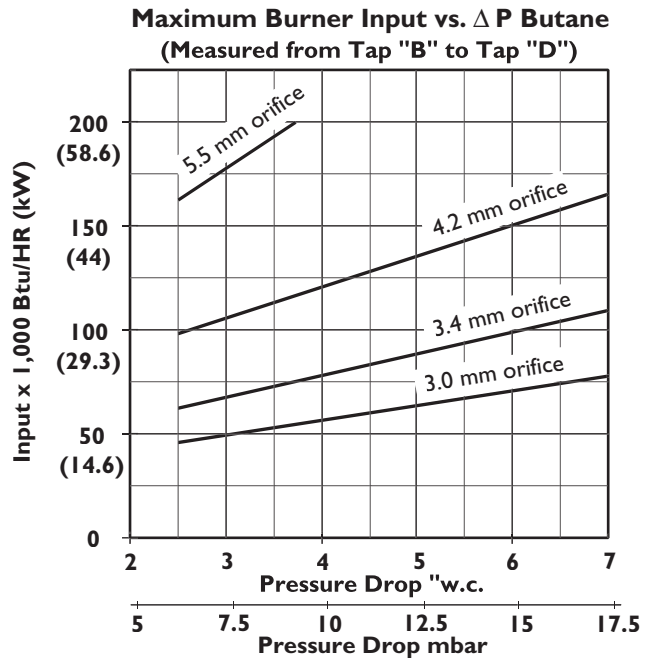
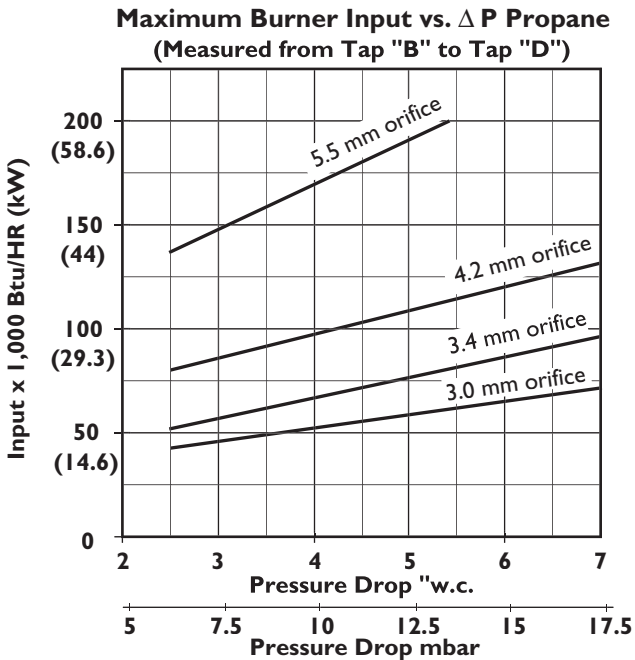
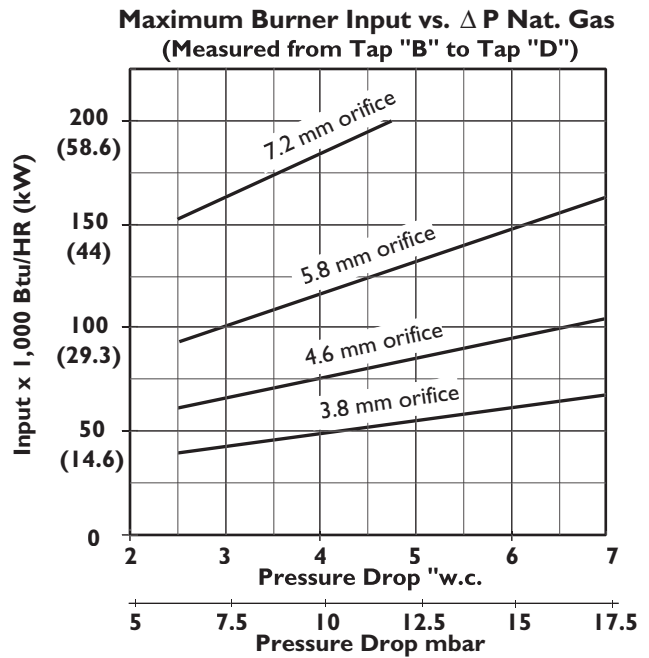
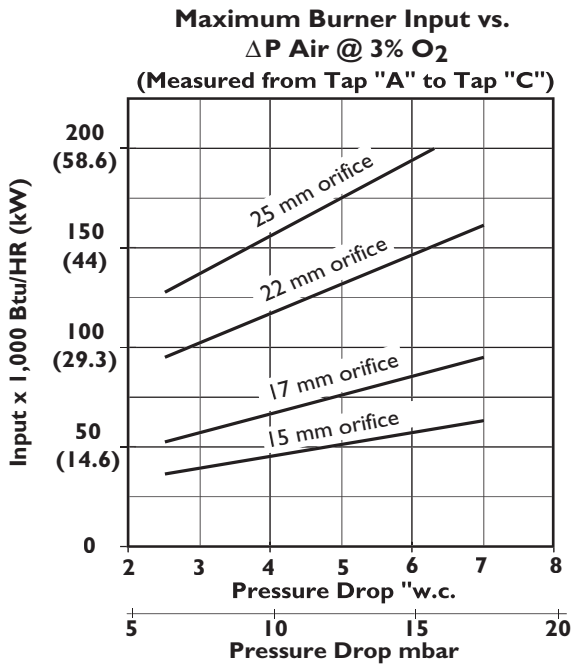
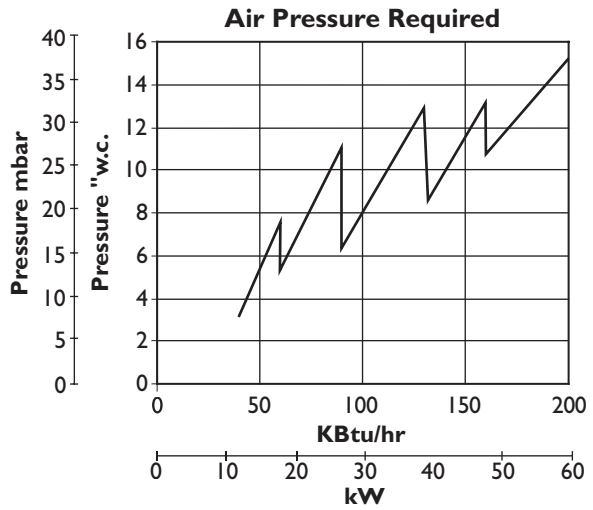
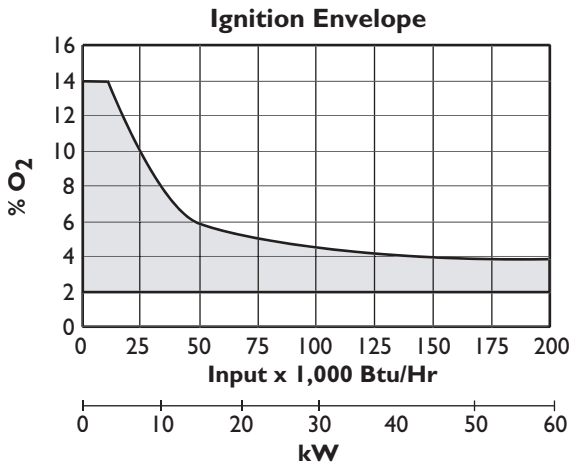

Performance Graphs (Cont.)
SER600 v3.00

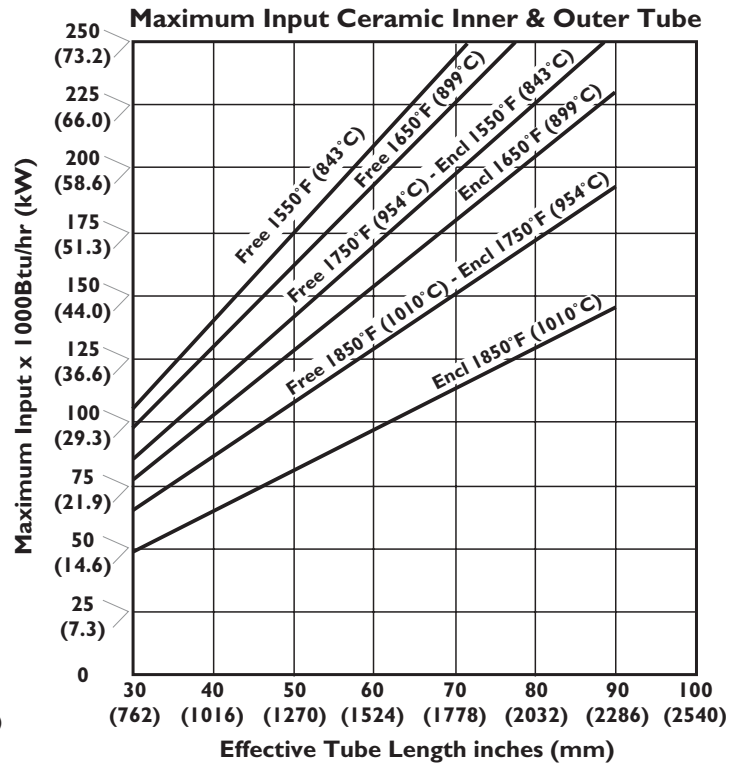
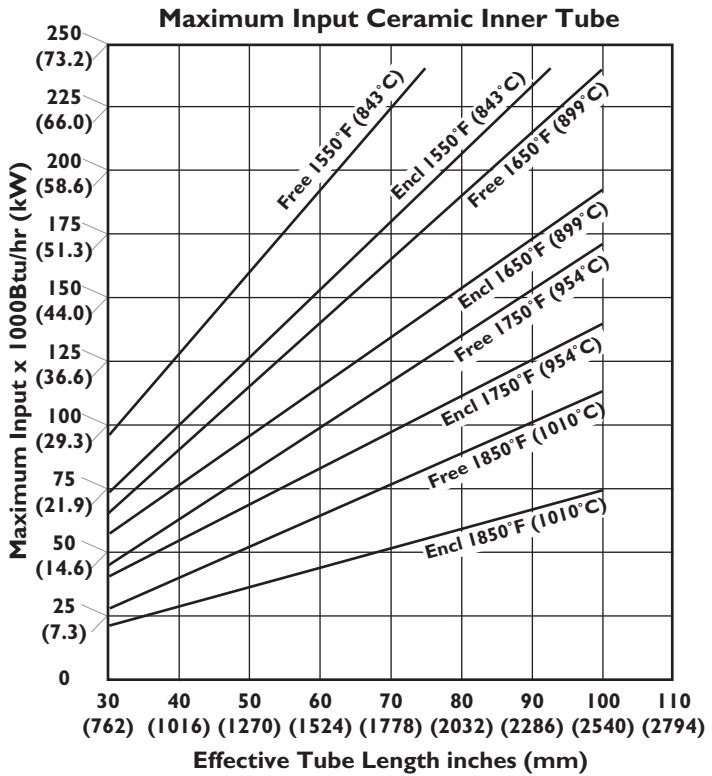
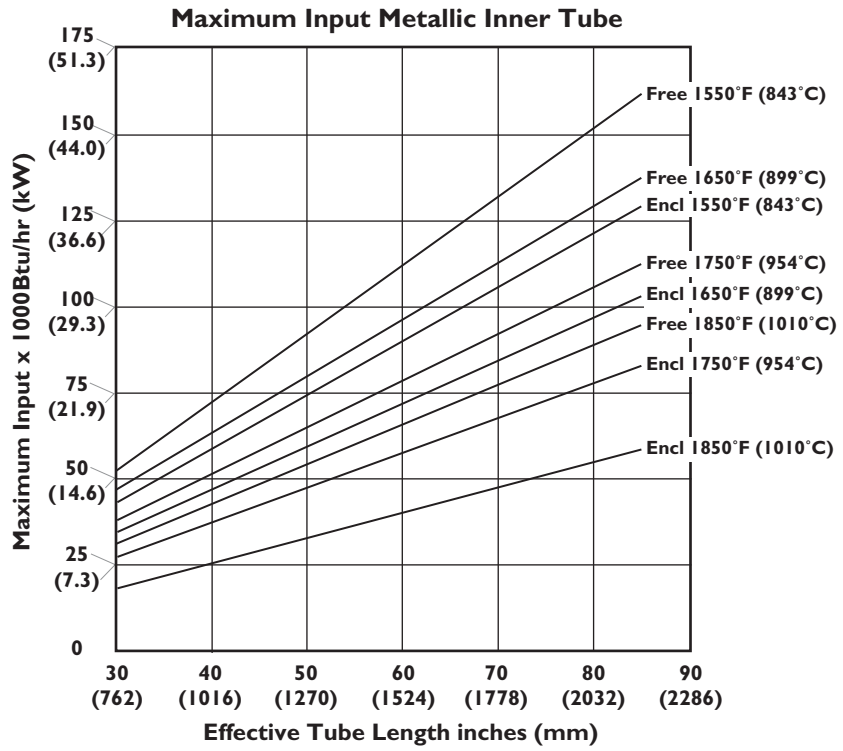
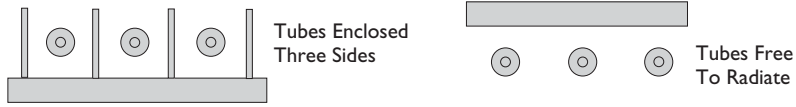

Dimensions & Specifications

SER600 v3.00

Dimensions in mm (Inches)

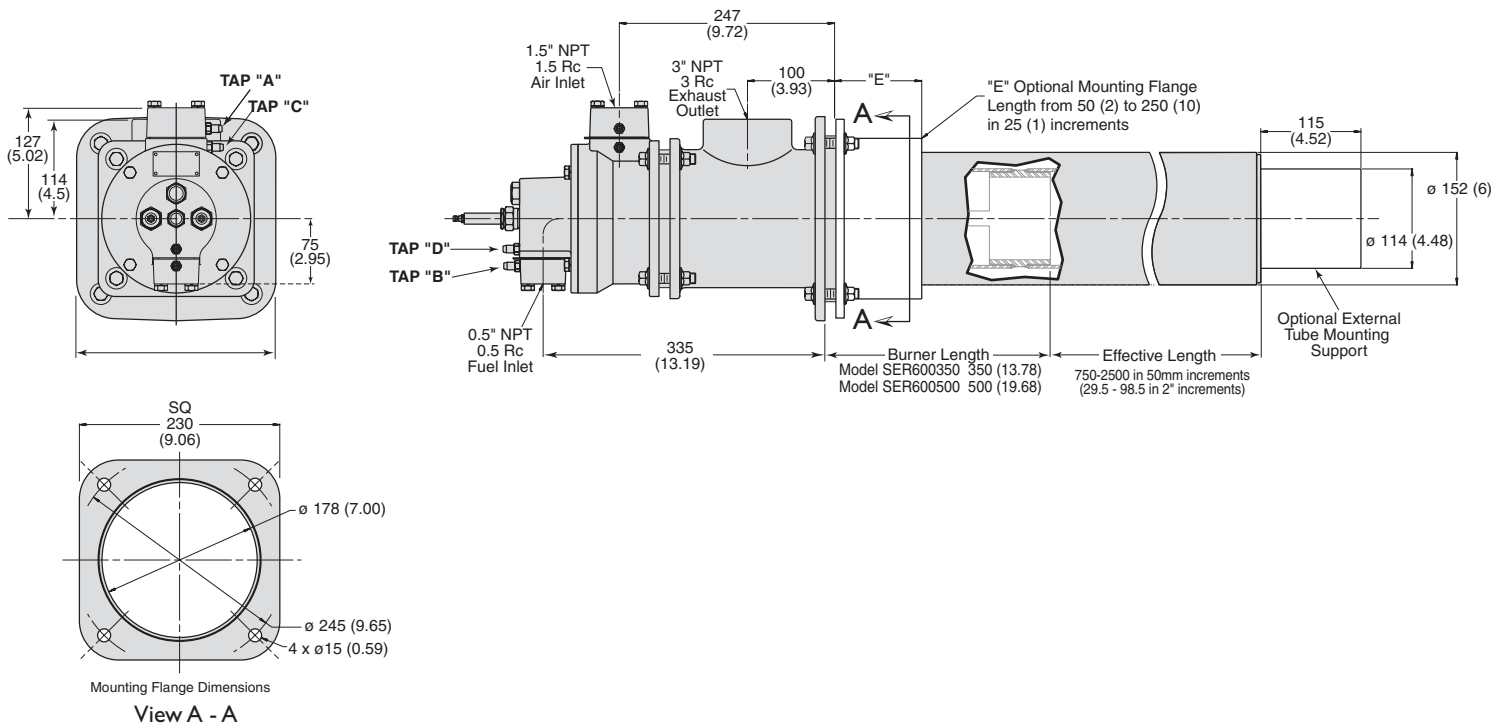

Eclipse Combustion

ISO 9001 Registered



Offered By:

Power Equipment Company
2011 Williamsburg Road
Richmond, Virginia 23231
Phone (804) 236-3800
Fax (804) 236-3882

www.peconet.com